

# GEALAN-LINEAR®

Design meets Function

# GEALAN-LINEAR®

## Positioning

- New GEALAN system that forms **a class of its own** in the 74-76 mm installation depth category
- Complete orientation to trends in architecture towards **straight-line, angular window design**
- The system is an extension of the product range with 74 mm installation depth by a **new efficient middle sealing system**. In return, the S 7000 IQ system will be purged at the end of 2021.
- The system is a supplement to the existing S 8000 IQ rebate sealing system and the GEALAN-SMOOVIO sliding solution in the price-sensitive market segment with 74 mm construction depth.
- There is a clear differentiation from the premium area with 82.5 mm construction depth (S 9000 AD/MD, GEALAN-KUBUS and the lift-slide door S 9000 HST)
- In the future, acrylcolor is not to be offered in systems with 74 mm depth. The cleanup of acrylcolor in S 8000 is planned.
- **GEALAN-LINEAR will not be available in acrylcolor.**

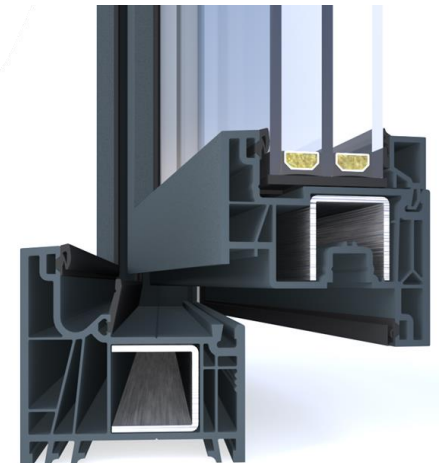

# GEALAN-LINEAR®

## Positioning

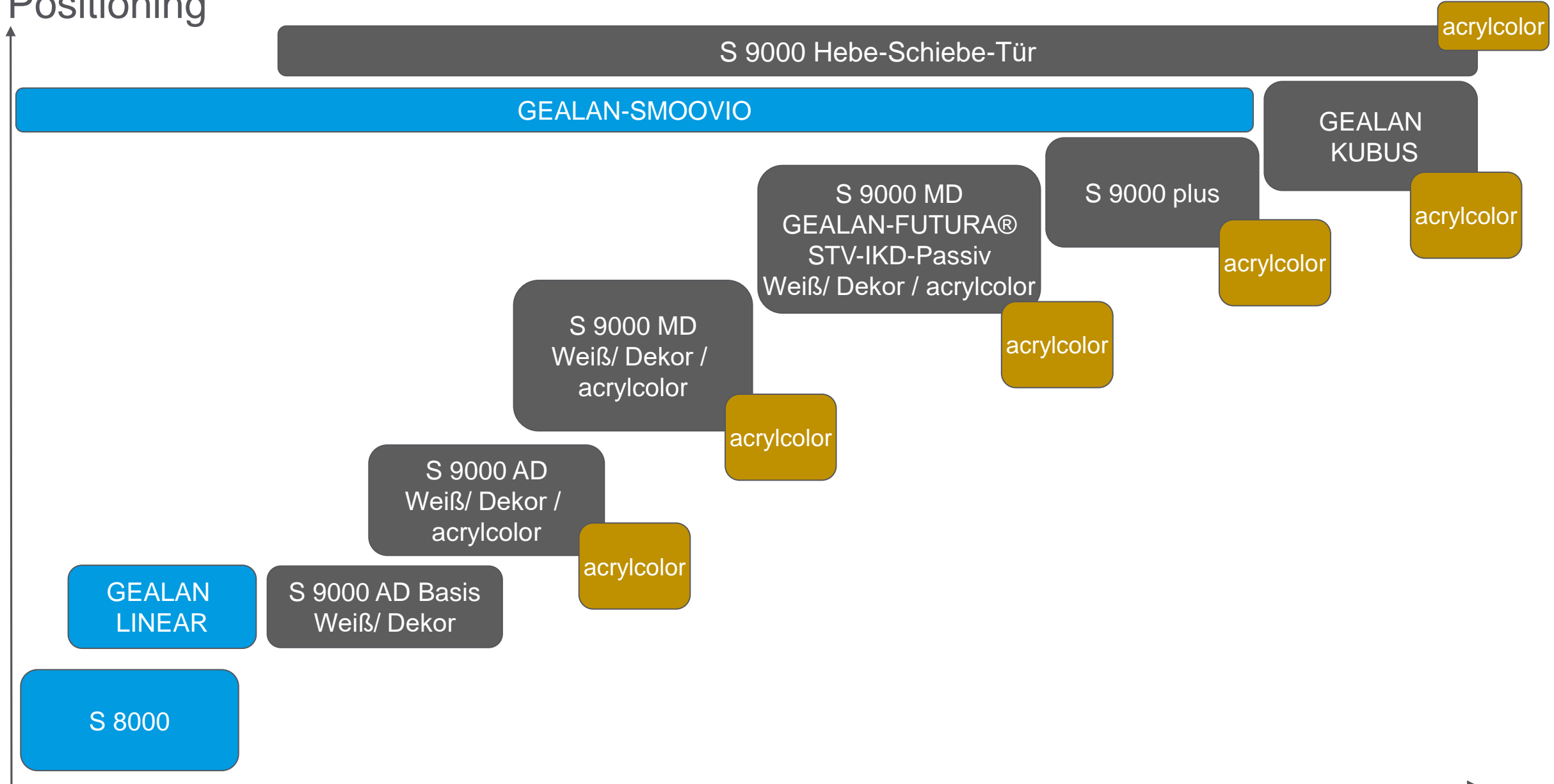

# GEALAN-LINEAR®

## Product highlights

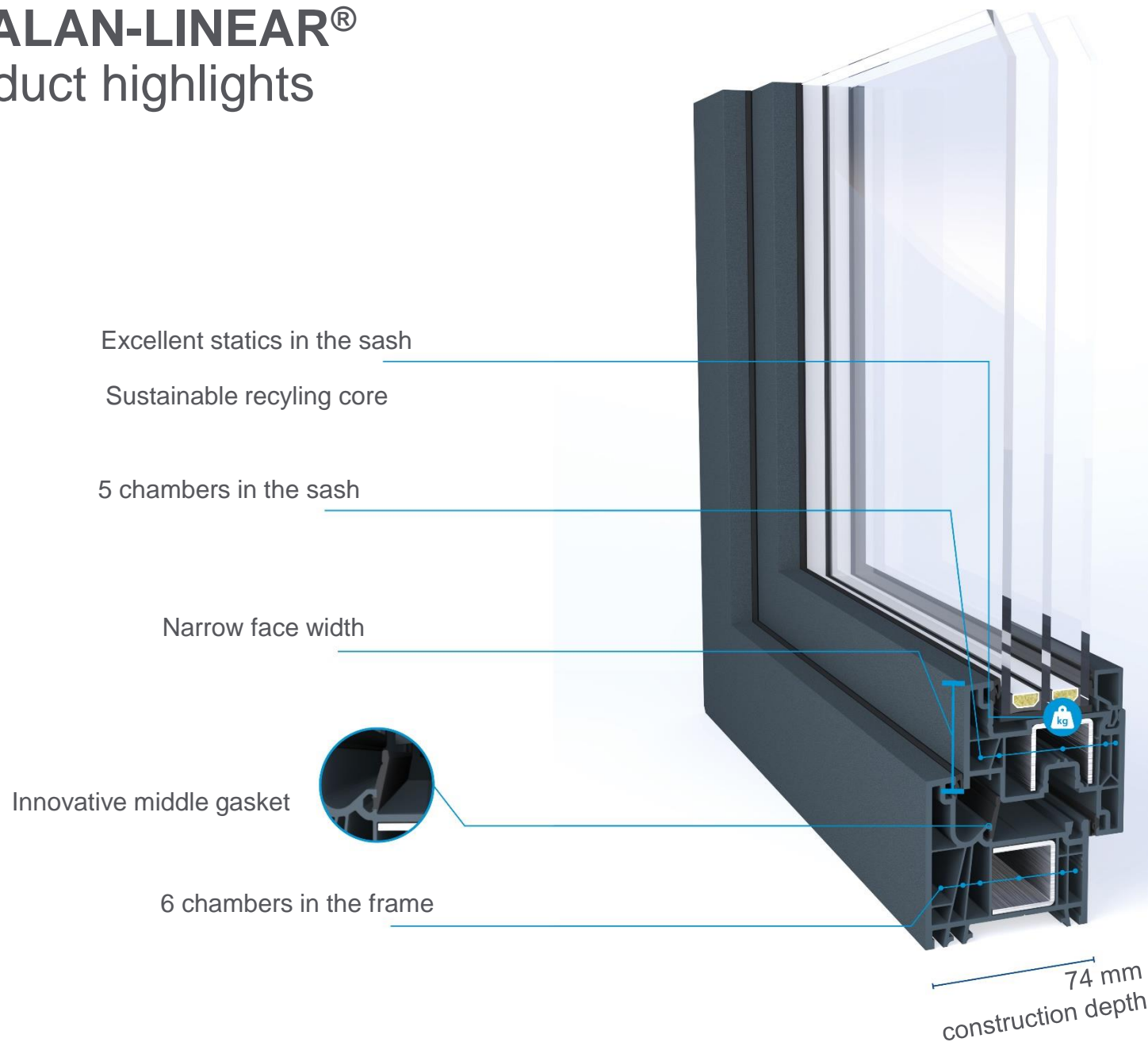

### ***Ideal for many construction situations***

*The narrow construction depth of 74 mm is suitable for a variety of construction projects as well as in the renovation sector. The universal sash rebate is integrated in all window sashes and allows for classic blocking, bonding with GEALAN-STV® or production optimised wet bonding.*

## **GEALAN-LINEAR®**

meets the highest demands for a profile with 70 mm+ construction depth in

**Design**

**Performance**

**Economic efficiency**

**Versatility**

This has been the goal of product development from the very beginning



A close-up photograph of a window frame, showing the dark grey or black frame and the glass panes. The background is blurred, showing a light-colored wall and a window sill. A blue rectangular overlay is positioned on the left side of the image, containing white text.

## Design

With its simple and clear form both outside and inside, the system also sets accents in terms of design.

Narrow face widths provide more light through a maximum amount of glass in the window.

# GEALAN-LINEAR® Design

- The profile overlaps with a 4° slant ensure a modern, straight-lined design language.
- Matching glazing beads with angular appearance are available for the inside.
- The system has narrow face widths in all installation situations. This results in slim profile elevations and maximises the proportion of glass.

Trend orientation to straight-line, angular window designs based on the model of aluminium windows

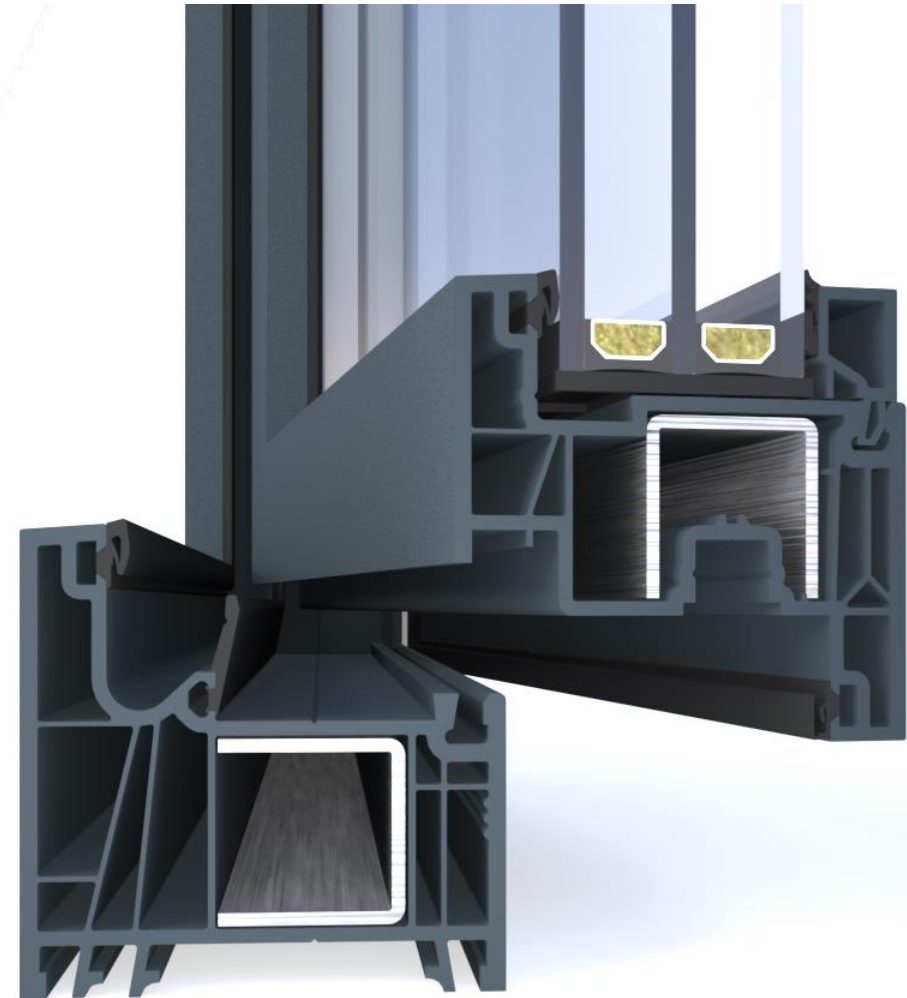

# GEALAN-LINEAR®

## Decorative foils

GEALAN offers standard foils in line with market requirements, supplemented by a wide selection of non-standard foils

- Foil coated profiles are available in various designs:
- Foil coated on the outside with a classic white surface on the inside
- Foil on both sides for a particularly high-quality appearance
- Different foil colours inside and outside for more flexibility and individual colour requests
- Foils with different surface structures are available:
  - Structured and smooth foils
  - foils with the unique RealWood surface

Note:

You can find the current decor foil program under [www.gealan.de](http://www.gealan.de)



## Performance

The middle sealing system achieves top performance values in the 74mm+ market segment by means of an innovative system construction, which is consistently designed to meet current and future market requirements.



# GEALAN-LINEAR®

## Technical core features

- 74 mm construction depth in frame and sash
- Three sealing levels for optimum thermal insulation
- Glass thicknesses from 24 to 48 mm (with STV up to 50 mm) applicable
- 4° slant in overturn
- 13 mm overlap width
- Five chambers in the sash, six chambers in the frame
- Proven technology of glazing bead mounting and single glazing bead
- Frame back suitable for existing 74 mm platform

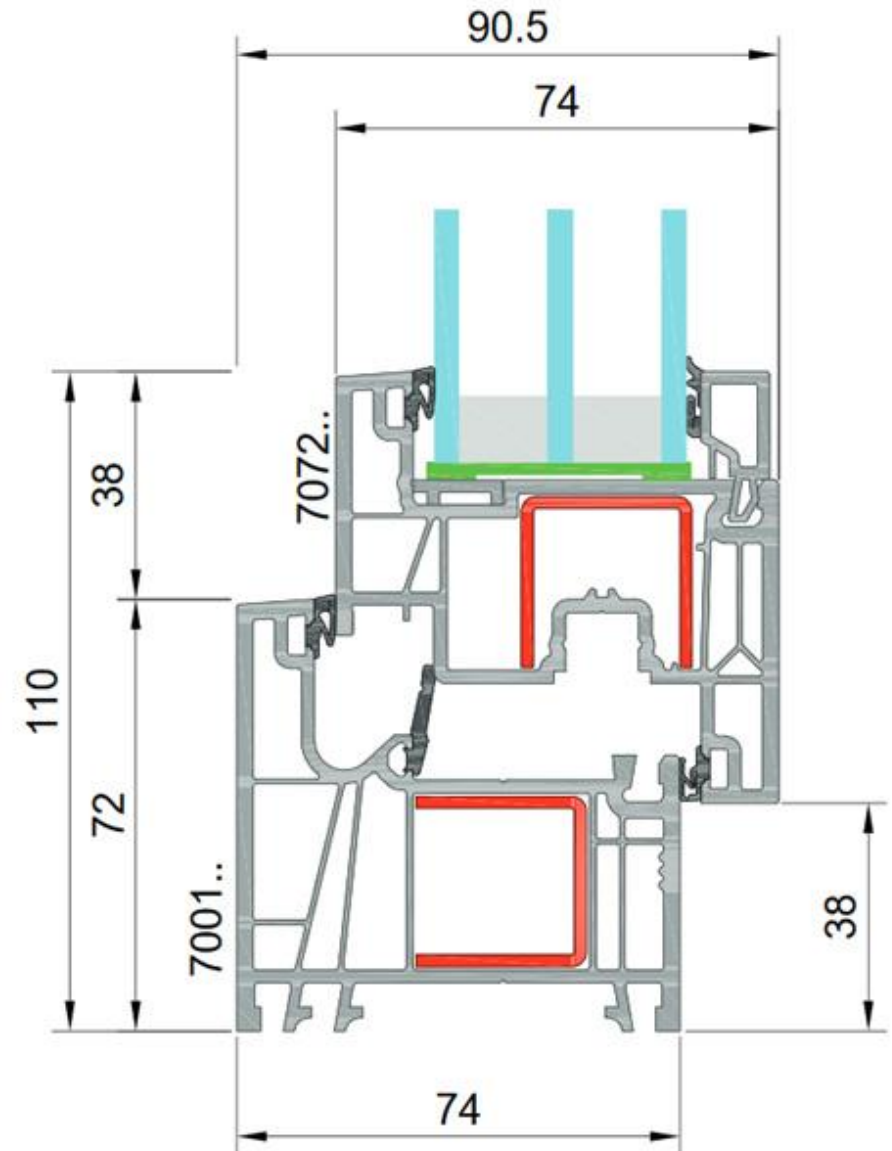

# GEALAN-LINEAR® Sealing

- Three sealing levels throughout ensure optimal impermeability and thermal insulation.
- The proven rebate seals on frame and sash ensure high impermeability and reduced closing forces.
- The newly designed middle seal level offers a high degree of processing convenience and cost-effectiveness.

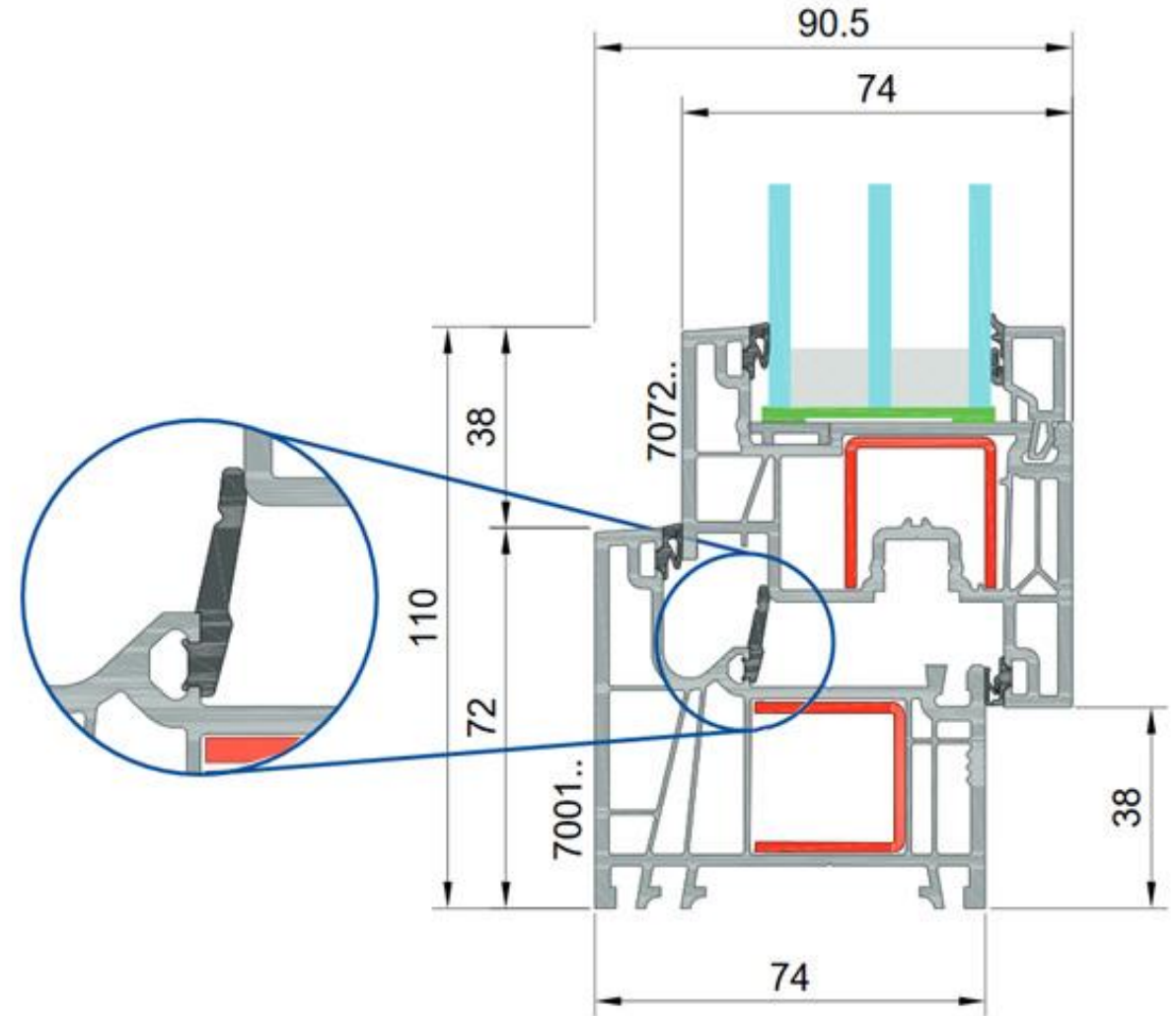

# GEALAN-LINEAR®

## Bonding technology in the window

- The universal sash rebate enables either classic blocking, gluing with STV® or wet bonding.
- The optimized rebate geometry ensures cost minimization for glass edge bonding in the RC2 and RC3 range
- The combination of wet bonding and STV® enables the minimization of drying times

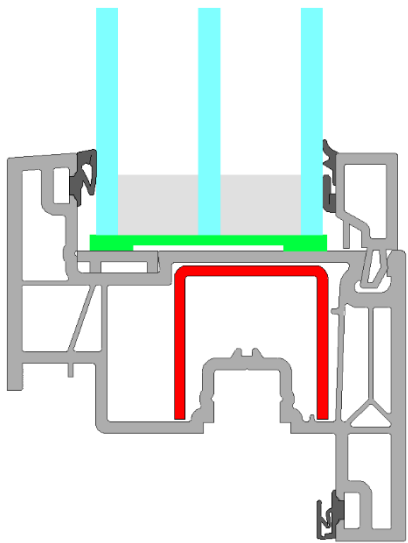

*Blocking without glue*

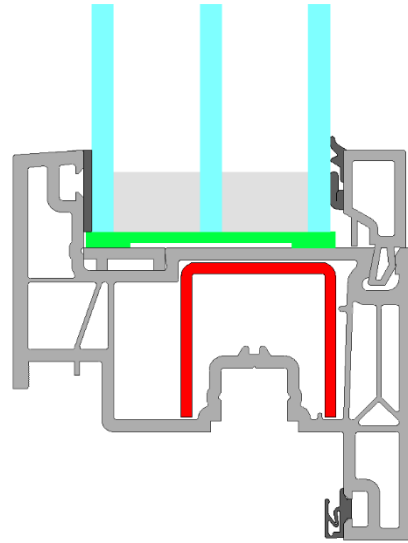

*Bonding with STV®*

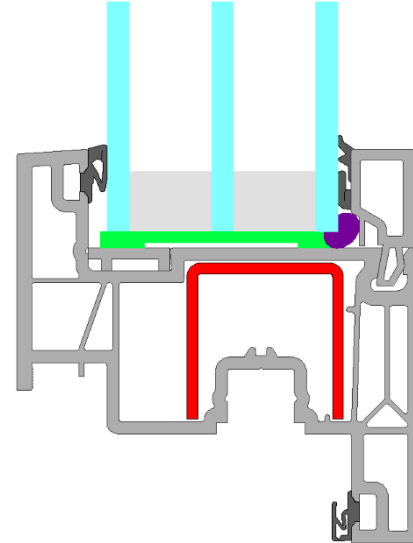

*Wet gluing*

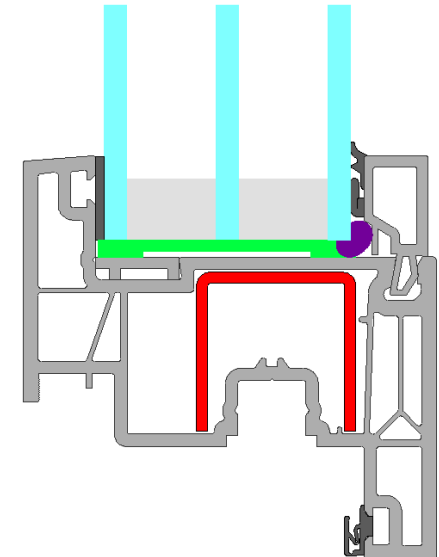

*Wet gluing and STV®*

# GEALAN-LINEAR®

## Bonding technology in the window

### The proven STV® bonding technology offers numerous advantages

- Activation of the glass panel for stiffening the individual elements
- Extension of the maximum element sizes in combination with steel stiffeners
- Improved thermal insulation and reduced element weights possible by dispensing with steel stiffeners
- Profile constructions with very narrow face widths can be realised
- Noticeably more stability in the sash due to higher torsional stiffness
- Adjustment and readjustment work on the window is reduced to a minimum
- Simple replacement of panes

### Further advantages can be achieved by wet bonding

- Rational processing due to high automation
- Resistance class RC2/RC3

# GEALAN-LINEAR® Drainage

- Same position of the drainage openings as with all other GEALAN systems.
- Same angle setting with  $55^\circ$  for the milling cutters is the same for all frames and sash profiles.

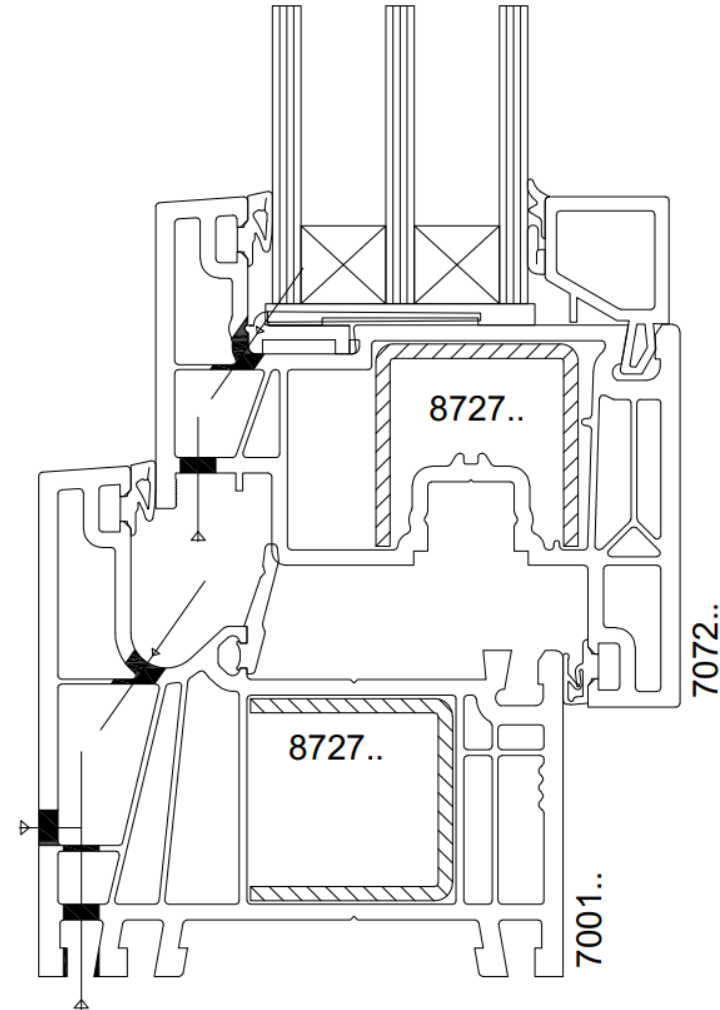

# GEALAN-LINEAR®

## Thermal insulation

- The system has good thermal insulation properties at a construction depth of 74 mm.
- The middle seal ensures an interruption of the heat flow.
- IFT Rosenheim confirmed excellent  $U_f$  values of up to **1.0 W/(m<sup>2</sup>K)** achieved in the system.
- Even the standard combination with 2.0 mm steels has a  $U_f$  value of **1.1 W/(m<sup>2</sup>K)**.



# GEALAN-LINEAR®

## Thermal insulation

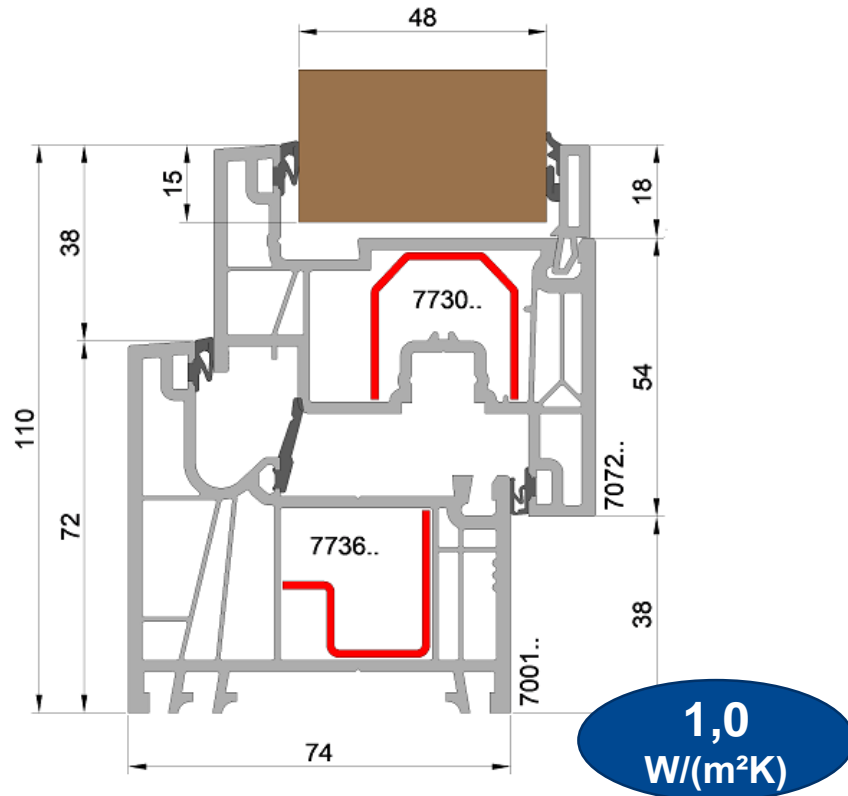

### ift-Nachweis

Nummer	20-001867-PR02 (NW-K20-06-de-01)
Inhaber	GEALAN Fenster-Systeme GmbH Hofer Str. 80 95145 Oberkotzau Deutschland
Produkt	Kunststoffprofil, Profilkombination: Flügelrahmen - Blendrahmen
Bezeichnung	System: GEALAN-LINEAR
Details	Material: Polyvinylchlorid hart (PVC-U); Ansichtsbreite 110 mm; Systembauliefe 74 mm; Flügelrahmen: Bezeichnung 7072; Querschnitt (B x D) 72 mm x 74 mm; Füllung Dicke 48 mm; Füllung Einstand 15 mm; Aussteifungsmaterial Stahl - verzinkter Stahl; Aussteifung Bezeichnung 7730; Blendrahmen: Bezeichnung 7001; Querschnitt (B x D) 72 mm x 74 mm; Aussteifungsmaterial Stahl - verzinkter Stahl; Aussteifung Bezeichnung 7736

Besonderheiten

Ergebnis

Wärmedurchgangskoeffizient nach EN 12412-2:2003-07

**$U_f = 1,0 \text{ W/(m}^2\text{K)}$**

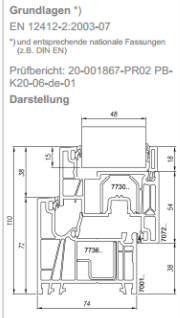

Verwendungshinweise

Die ermittelten Ergebnisse können für den Nachweis entsprechend den oben angegebenen Grundlagen verwendet werden.

Gültigkeit

Zeitlich nicht limitiert.

Bei der Anwendung sind die Aktualität der Grundlagen sowie die Übereinstimmung des Produkts zu beachten.

Die genannten Daten und Einzelergebnisse beziehen sich ausschließlich auf den geprüften/beschriebenen Probekörper. Die Prüfung ermöglicht keine Aussage über weitere leistungs- und qualitätsbestimmende Eigenschaften des vorliegenden Produkts.

Veröffentlichungshinweise

Es gilt das "Merkblatt zur Benutzung von ift-Prüfdokumentationen".

ift Rosenheim  
16.07.2020

Konrad Huber, Dipl.-Ing. (FH)  
Prüfstellenleiter  
Bauphysik

Stefan Junker, Dipl.-Ing. (FH)  
Prüfingenieur  
Bauphysik



[www.ift-rosenheim.de/ift-geprueft](http://www.ift-rosenheim.de/ift-geprueft)  
ID: 729-F7388



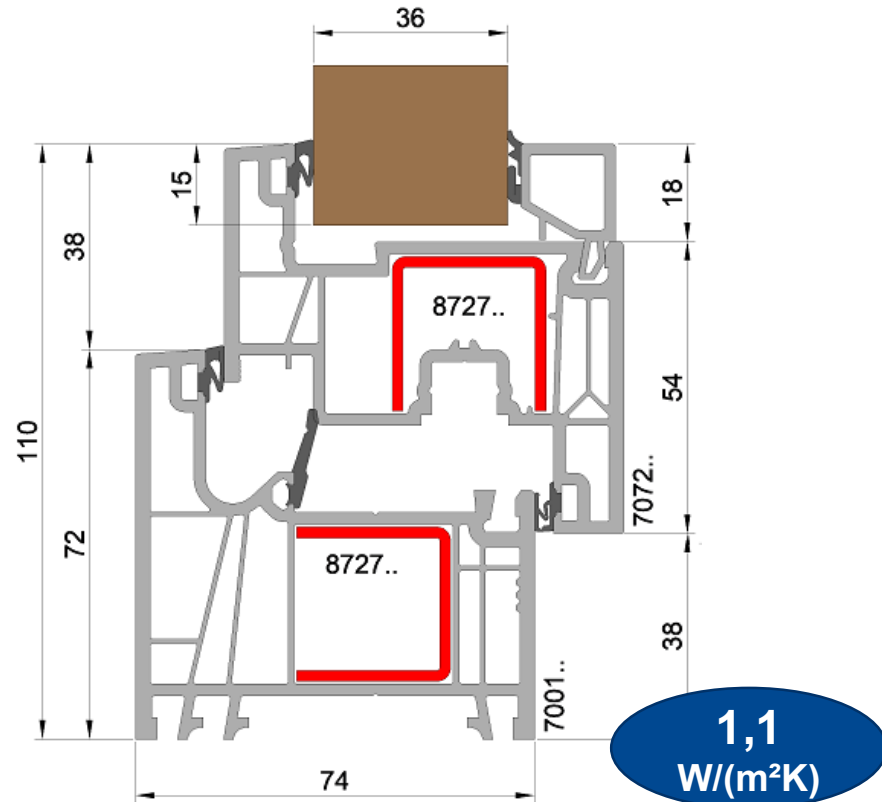

VerPB14172-246 (01.06.2019)

# GEALAN-LINEAR®

## Thermal insulation

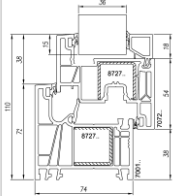

Suitable for colour windows

<b>ift-Nachweis</b>		
<b>Nummer</b>	20-001867-PR01 (NW-K20-06-de-01)	<b>Grundlagen *)</b> EN 12412-2:2003-07 <small>*) und entsprechende nationale Fassungen (z.B. DIN EN)</small>
<b>Inhaber</b>	GEALAN Fenster-Systeme GmbH Hofer Str. 80 95145 Oberkotzau Deutschland	Prüfbericht: 20-001867-PR01 PB-K20-06-de-01 <b>Darstellung</b>
<b>Produkt</b>	Kunststoffprofil, Profilkombination: <b>Flügelrahmen - Blendrahmen</b>	
<b>Bezeichnung</b>	System: GEALAN-LINEAR	<b>Verwendungshinweise</b>
<b>Details</b>	Material <b>Polyvinylchlorid hart (PVC-U)</b> ; Ansichtsbreite <b>110 mm</b> ; Systembauleife <b>74 mm</b> ; Flügelrahmen: Bezeichnung <b>7072</b> ; Querschnitt (B x D) <b>72 mm x 74 mm</b> ; Füllung Dicke <b>36 mm</b> ; Füllung Einstand <b>15 mm</b> ; Aussteifungsmaterial <b>Stahl - verzinkter Stahl</b> ; Aussteifung Bezeichnung <b>8727</b> ; Blendrahmen: Bezeichnung <b>7001</b> ; Querschnitt (B x D) <b>72 mm x 74 mm</b> ; Aussteifungsmaterial <b>Stahl - verzinkter Stahl</b> ; Aussteifung Bezeichnung <b>8727</b>	Die ermittelten Ergebnisse können für den Nachweis entsprechend den oben angegebenen Grundlagen verwendet werden. <b>Gültigkeit</b> Zeitlich nicht limitiert. Bei der Anwendung sind die Aktualität der Grundlagen sowie die Übereinstimmung des Produkts zu beachten.
<b>Besonderheiten</b>		Die genannten Daten und Einzelergebnisse beziehen sich ausschließlich auf den geprüften/beschriebenen Probekörper. Die Prüfung ermöglicht keine Aussage über weitere leistungs- und qualitätsbestimmende Eigenschaften des vorliegenden Produkts.
<b>Ergebnis</b>	Wärmedurchgangskoeffizient nach EN 12412-2:2003-07  <b><math>U_f = 1,1 \text{ W/(m}^2\text{K)}</math></b>	<b>Veröffentlichungshinweise</b> Es gilt das "Merkblatt zur Benutzung von ift-Prüfdokumentationen".
<b>ift Rosenheim</b> 16.07.2020		<b>Identitäts-Check</b> 
 Konrad Huber, Dipl.-Ing. (FH) Prüfstellenleiter Bauphysik		 Stefan Linker, Dipl.-Ing. (FH) Prüfingenieur Bauphysik

# GEALAN-LINEAR®

## Fixed glazing

- For fixed glazing, glazing beads with a height of 26 mm are used.
- The glazing rebate width in frame and casement is identical. This results in a uniform glazing bead grid.
- Glazing thicknesses of up to 48 mm are also possible with fixed glazing.
- The middle seal can be cut off above the dome and does not have to be removed completely.

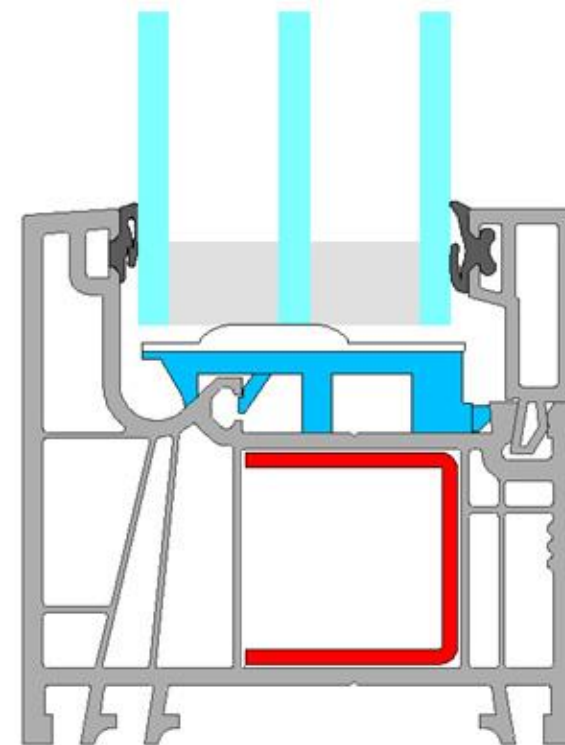

# GEALAN-LINEAR®

## Glazing beads with 90° design

- A wide variety of glazing beads with 18 mm and 26 mm height is available
- The glazing beads can be mitred or butt jointed.
- Optionally, it is also possible to use existing round glazing beads.
- Glazing beads for other glass thicknesses are in preparation

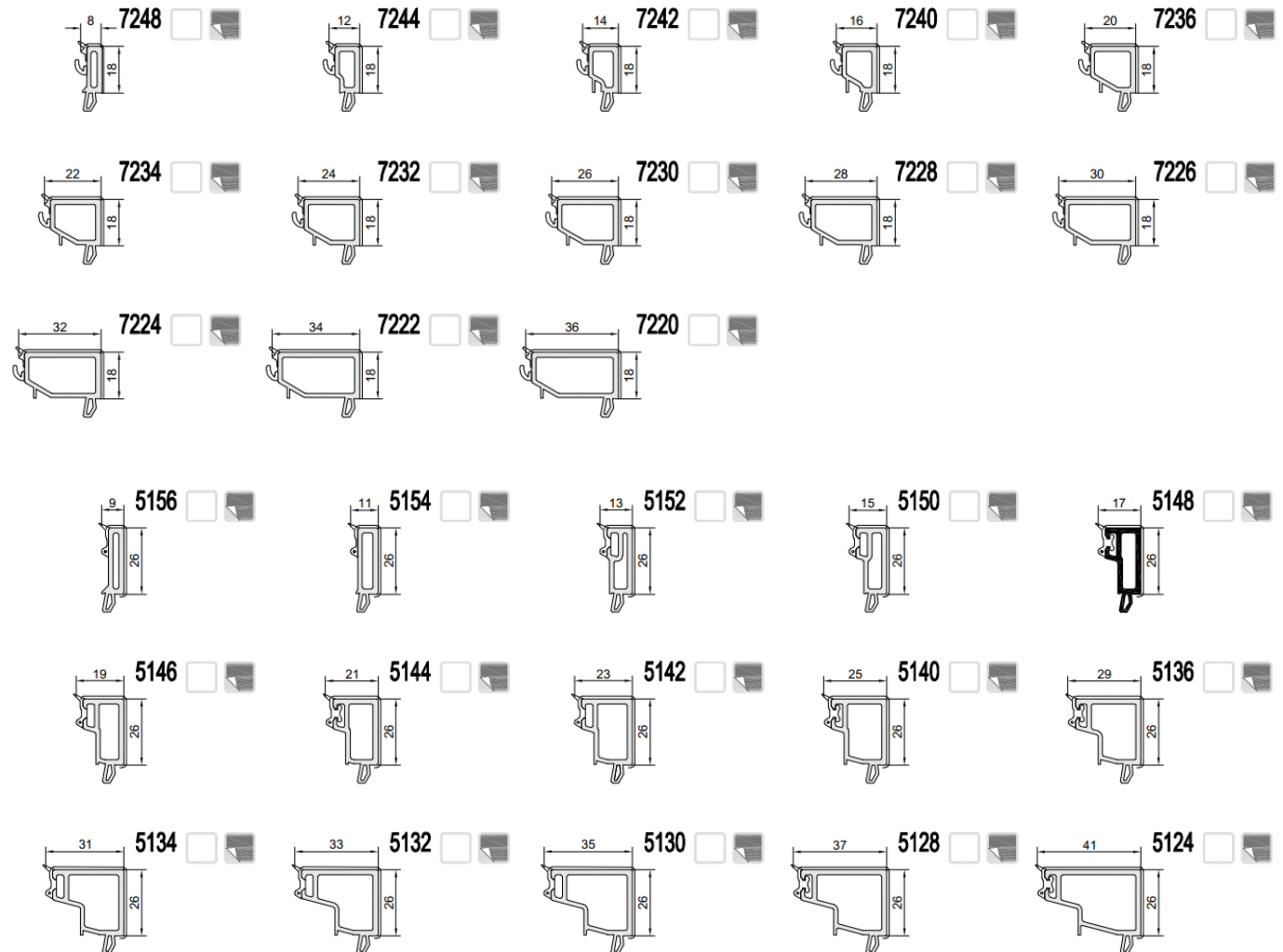

## Economic efficiency

Optimised profile constructions and innovative detailed solutions enable the system to be assembled quickly and easily. High compatibility within the system, but also with other GEALAN systems, reduces the number of required profiles, accessories and bracing.



# GEALAN-LINEAR®

## Reinforcement concept

- Due to the high level of compatibility within the system, only very few stiffening geometries are required to process the system.
- In addition, stiffeners from the existing systems were used extensively. This means that the number of steels required when processing several systems can be reduced to a minimum.

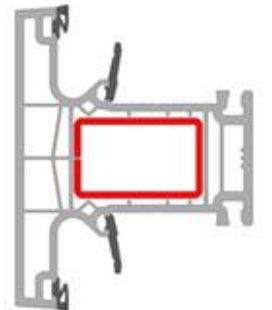
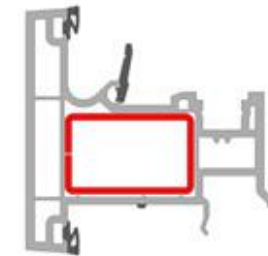
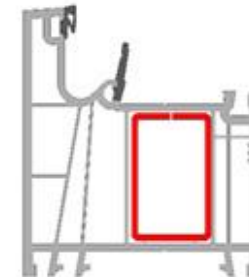
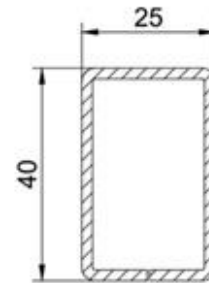
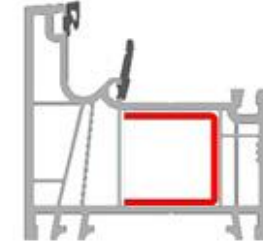
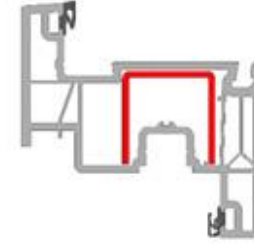
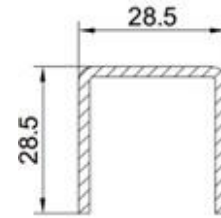

Optimised stock keeping:

When processing multiple systems, the number of steels required has been reduced to a minimum thanks to the use of existing steels

Example: Possibility of using standardized reinforcements

## Versatility

Due to the construction depth of 74 mm, a comprehensive range of existing additional profiles as well as numerous existing system solutions can be used. A new front door system and a visually adapted sash for the GEALAN-SMOOVIO sliding system complete the extensive system offer.

# GEALAN-LINEAR®

## Profile overview

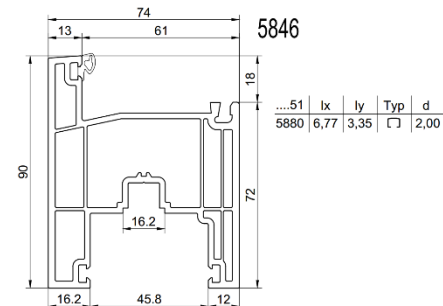
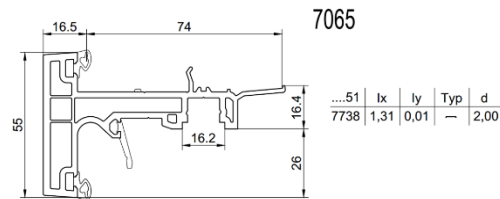
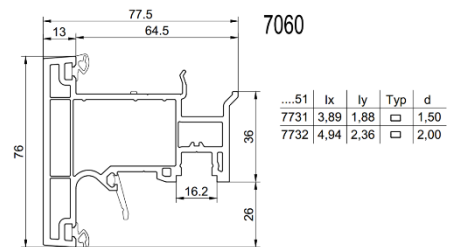
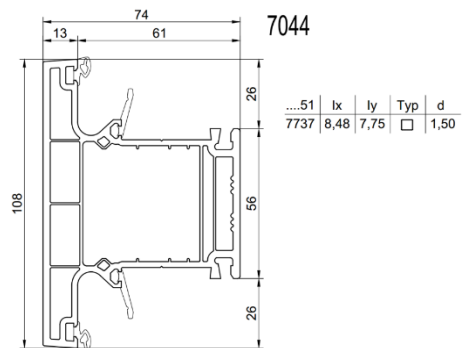
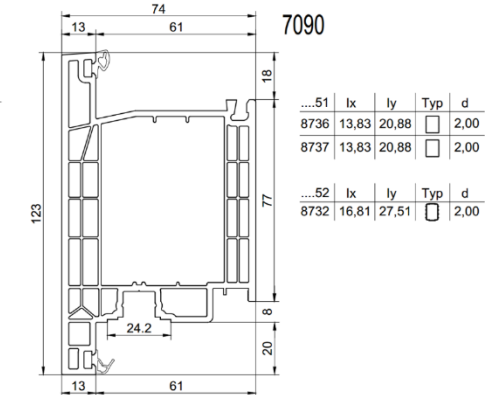
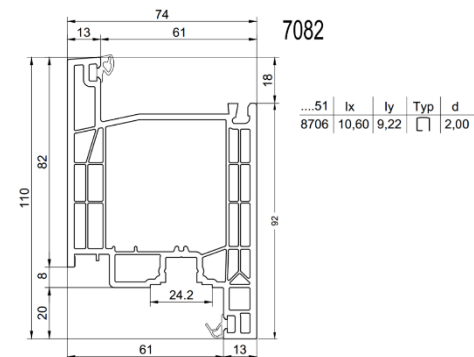
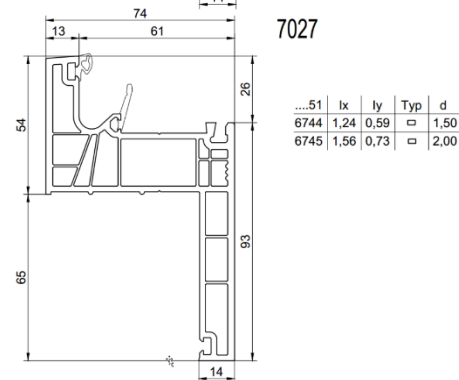
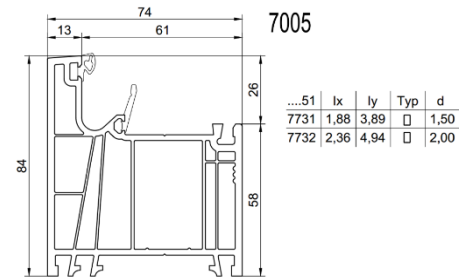
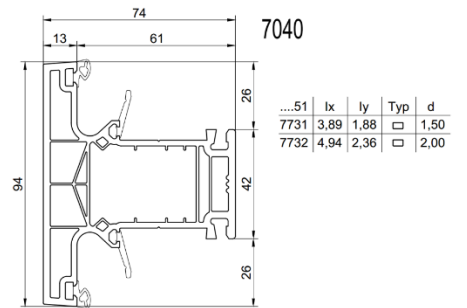
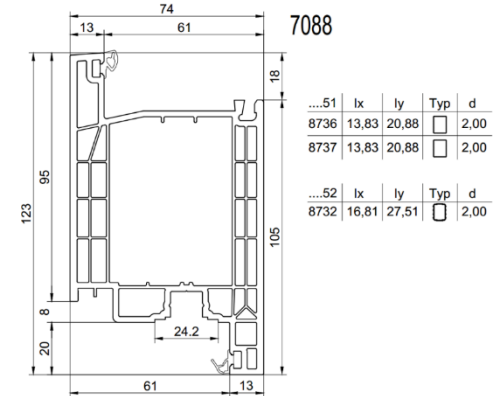
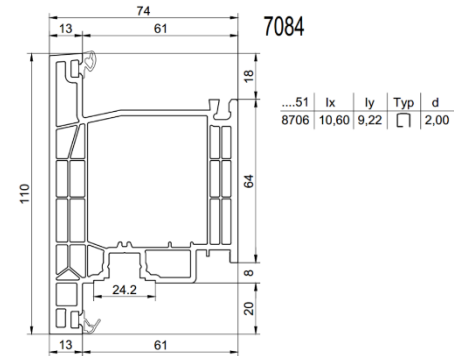
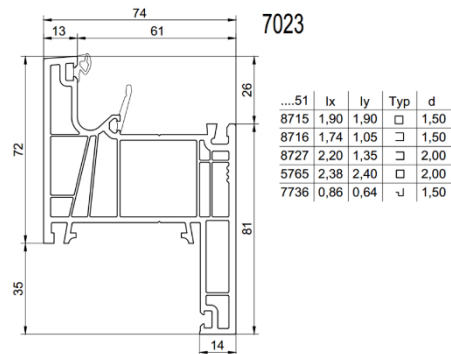
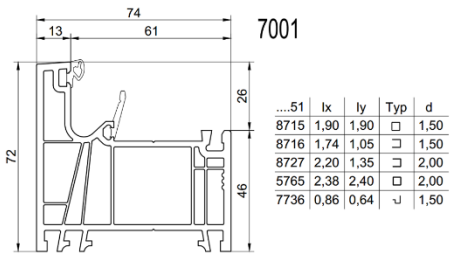
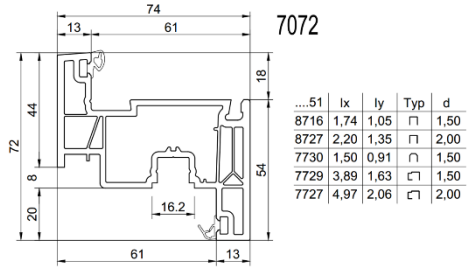

### Sash

- The flexible rebate geometry enables both classic blocking and efficient wet bonding. Optionally STV® can also be used.
- The steel chamber allows the variable use of different steel geometries. Depending on the requirements, steels can be used that are optimized in terms of statics or thermal insulation. It is also possible to use a uniform steel geometry in sash and frame.
- The possibility of using steels with an  $I_x$  of up to 4.97 means that excellent static values are achieved, which can be further improved by bonding the panes.
- Standard gears with 15 mm mandrel can be used with a face width of only 44 mm. This allows very narrow profile elevations to be achieved in all installation situations.

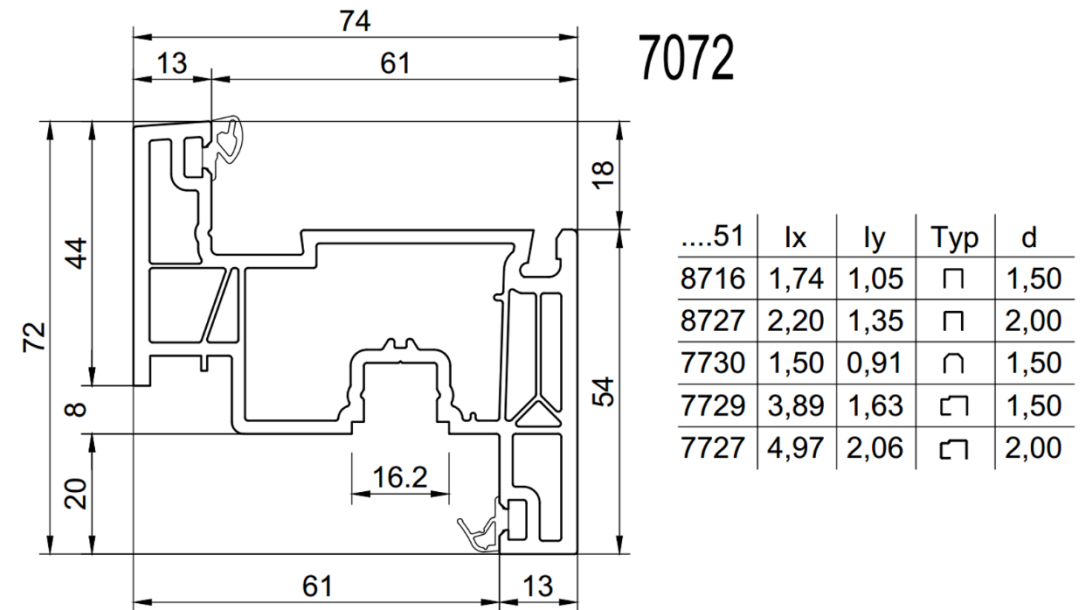

Narrow face widths in a construction situations

# GEALAN-LINEAR®

## System technology in detail

### Frame

- Through the targeted use of IKD, it is possible to further improve the thermal insulation. The use of steel stiffeners is still possible without restriction.
- Large profile antechambers in the frame profile allow for optimum ventilation and thus minimise heating of the profile. This principle was taken into account throughout the system.

6 chamber layout for ideal thermal insulation

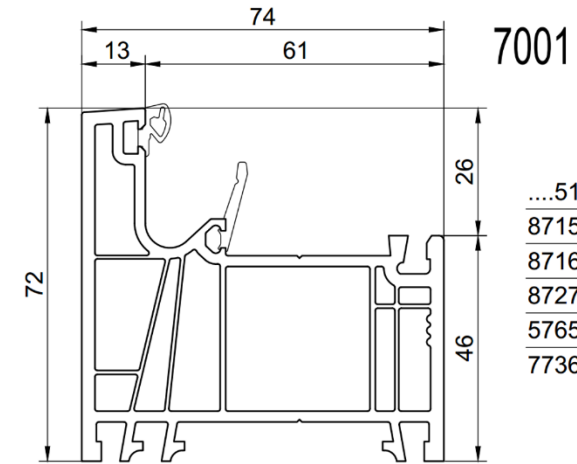

...51	lx	ly	Typ	d
8715	1,90	1,90	□	1,50
8716	1,74	1,05	□	1,50
8727	2,20	1,35	□	2,00
5765	2,38	2,40	□	2,00
7736	0,86	0,64	∩	1,50

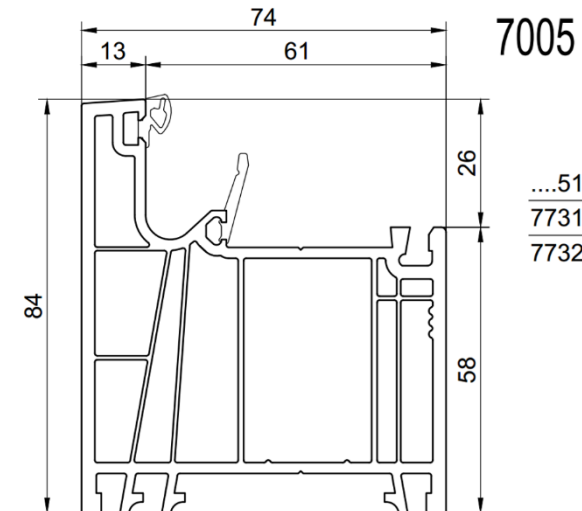

...51	lx	ly	Typ	d
7731	1,88	3,89	□	1,50
7732	2,36	4,94	□	2,00

### Mullion

- Large bracing chambers provide very good static properties.
- The post with 94 mm face width has a 5-chamber for good thermal insulation properties.
- For higher static requirements a mullion profile with 108 mm face width is available.

Very good statics due to large bracing chambers

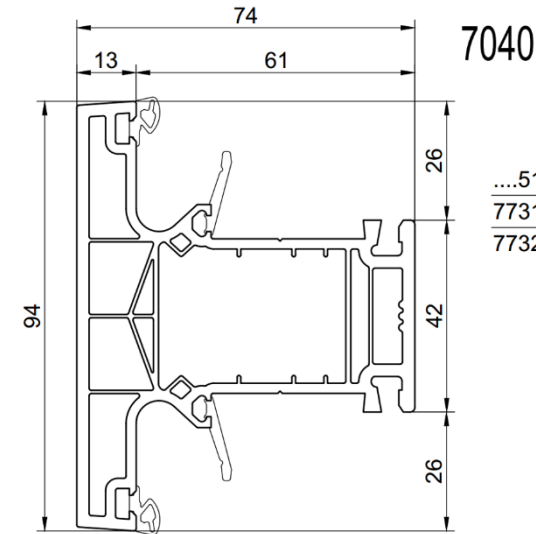

....51	Ix	Iy	Typ	d
7731	3,89	1,88	□	1,50
7732	4,94	2,36	□	2,00

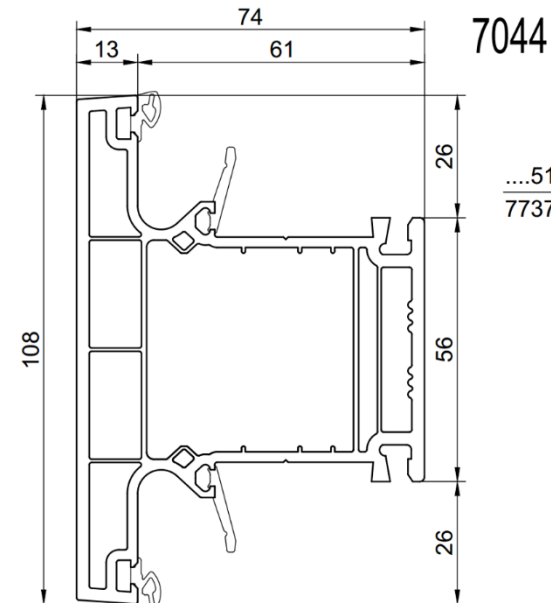

....51	Ix	Iy	Typ	d
7737	8,48	7,75	□	1,50

### Mullion

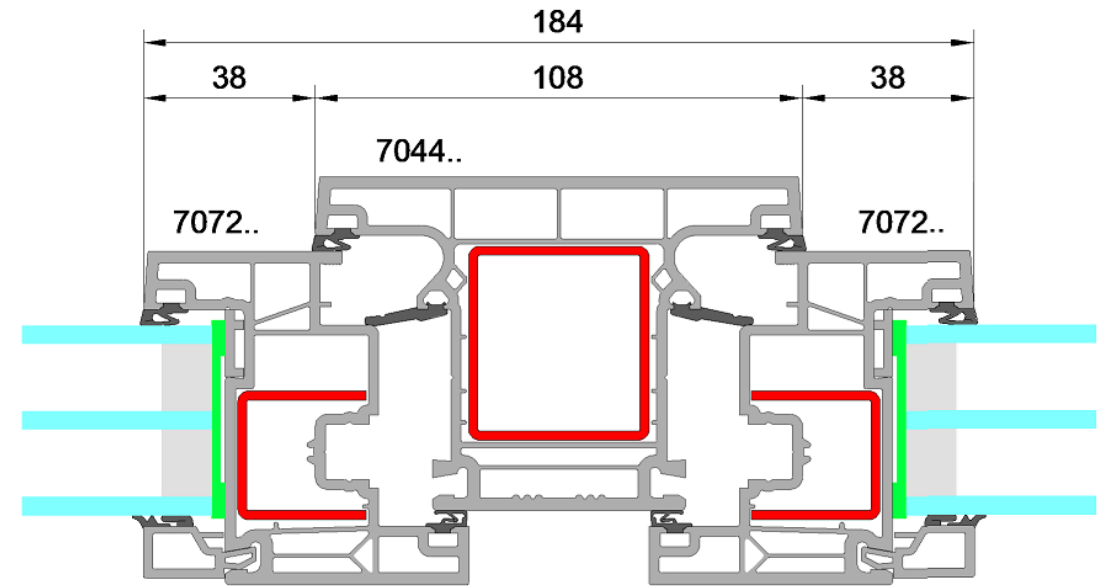
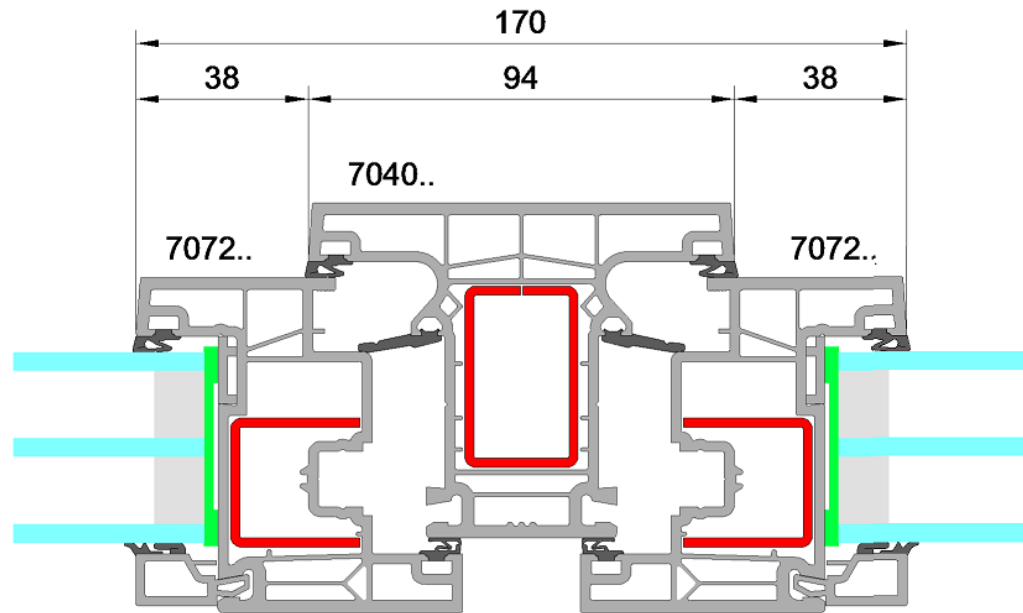

Due to the narrow sash geometry, the elevation widths in the mullion area are also narrow and at the same time very good statics.

# GEALAN-LINEAR®

## System technology in detail

### Mullion connectors

- All connector combinations of the GEALAN LINEAR system are designed for high processing speeds in machine window production.
- The metal connectors are characterized by high stability.
- The seals do not have to be notched and can pass through in the area of the mullion.
- The connector overlaps the profile and therefore always ensures a clean coverage of the cut edge.
- An additional sealing block is available for use as a transom, which seals the area in front of the middle gasket.
- Optional additional rebate corner angles can be used.

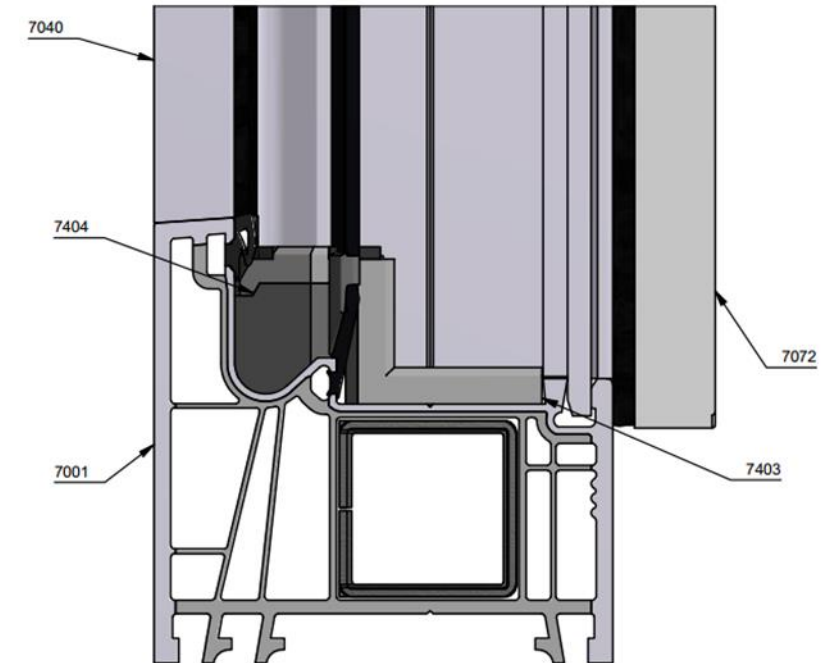
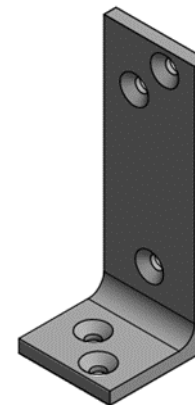
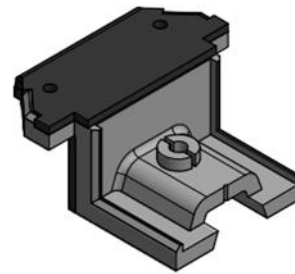
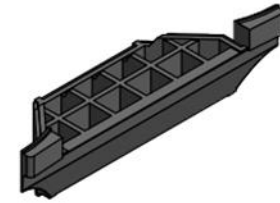

The middle gasket does not have to be released

### Casement

- Due to a sealing lip on the profile, no silicone insert is required for sealing between sash and casement.
- A large steel chamber in the 76 mm casement allows the use of tubular steel with very good static properties.
- The casement profiles clip onto the sash profile and can therefore be screwed together quickly and easily.
- Optionally, the casement profiles can also be screwed in a concealed manner from the sash rebate.

No silicone insert necessary between sash and casement

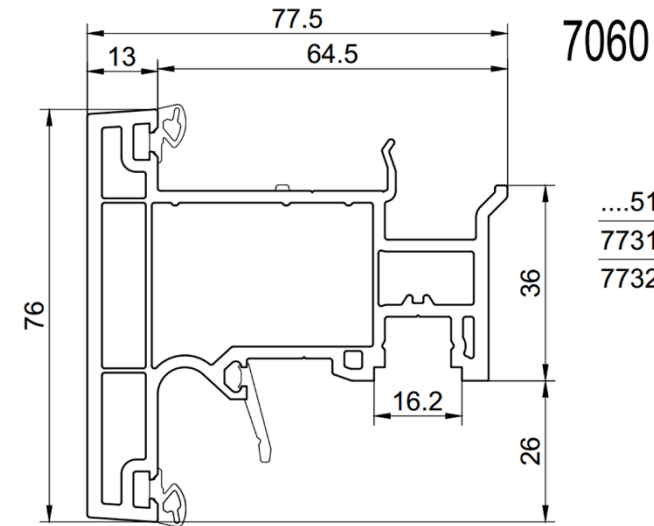

...51	lx	ly	Typ	d
7731	3,89	1,88	□	1,50
7732	4,94	2,36	□	2,00

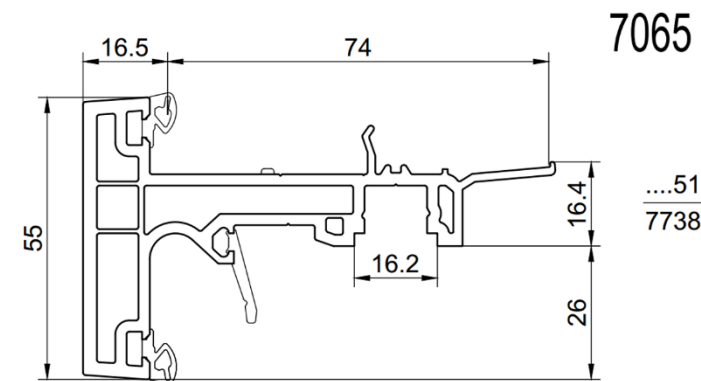

...51	lx	ly	Typ	d
7738	1,31	0,01	—	2,00

### Casement

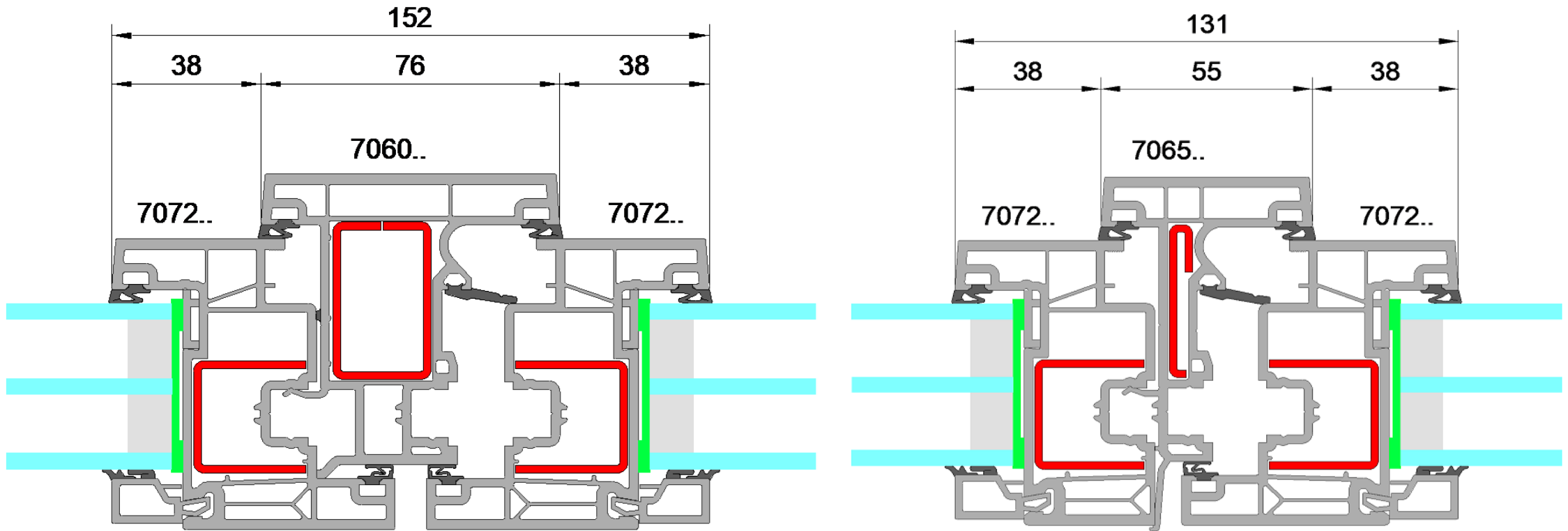

The system offers the narrowest face widths in the casement area. The retaining strip in the Euronut ensures simple and quick installation.

### Casement caps

- The two-part casement caps consist of a base cap and an outer cap and can therefore be colour-coordinated with the casement profile.
- The middle seal of the faceplate profile is continued in the casement base cap and thus ensures optimum sealing.

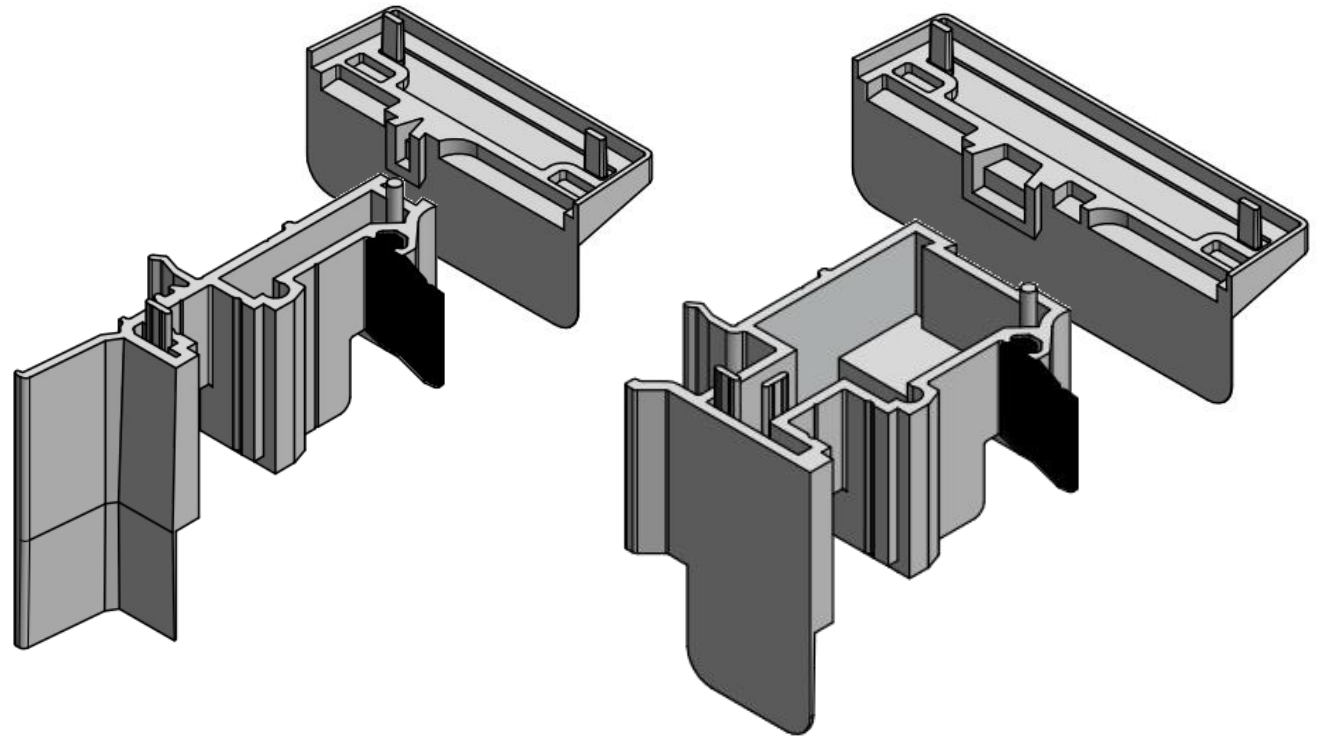

The colour of the casement caps can be matched to the colour of the forend profile

### Coupling

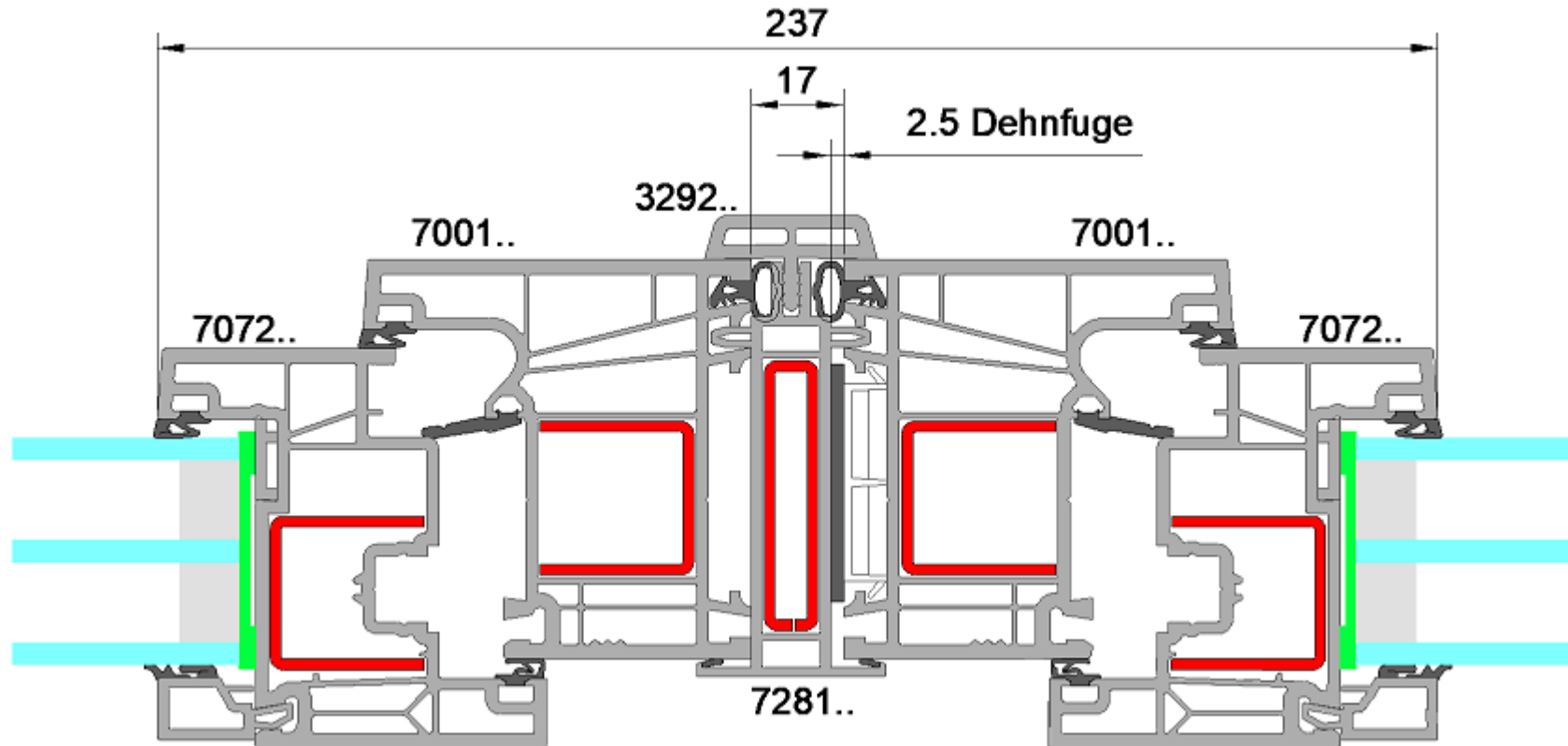

The proven coupling solution for 74 mm installation depth offers very good static properties.

### Coupling

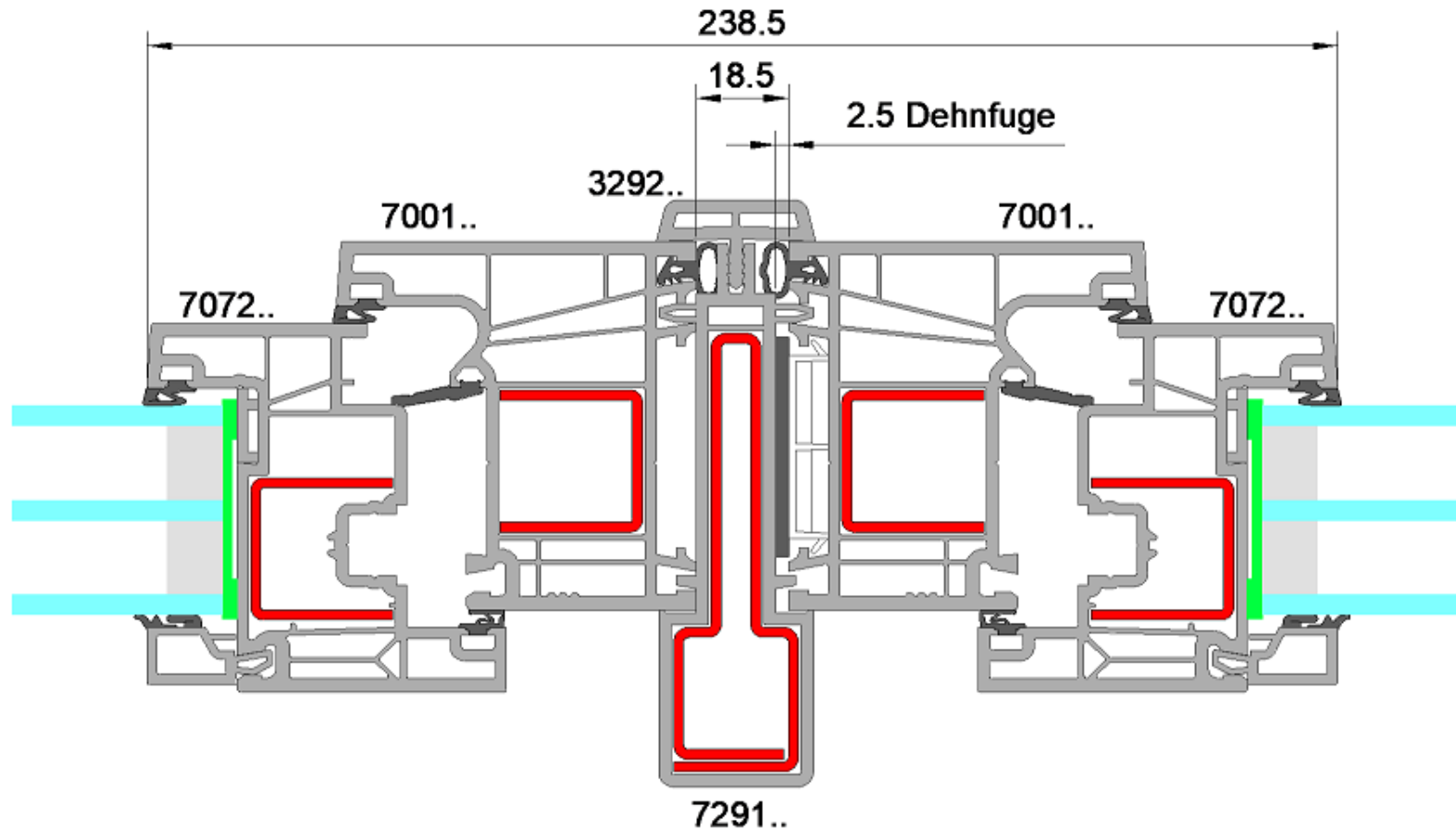

The coupling solution with internal pilaster strip offers maximum statics.

### Balcony door

- The wing profiles for balcony doors are based on the proven stiffening concept from the S 8000 system.
- The large steel chamber allows the use of a large dimensioned stiffener and locks with backset of up to 45 mm.
- The bracing can be used uniformly for the inward and outward opening sash.
- Weldable corner connectors are available for increased corner strength requirements.
- For increased static requirements the standard glass rebate allows the use of rebate stiffeners.

Proven bracing concept from the S 8000 system

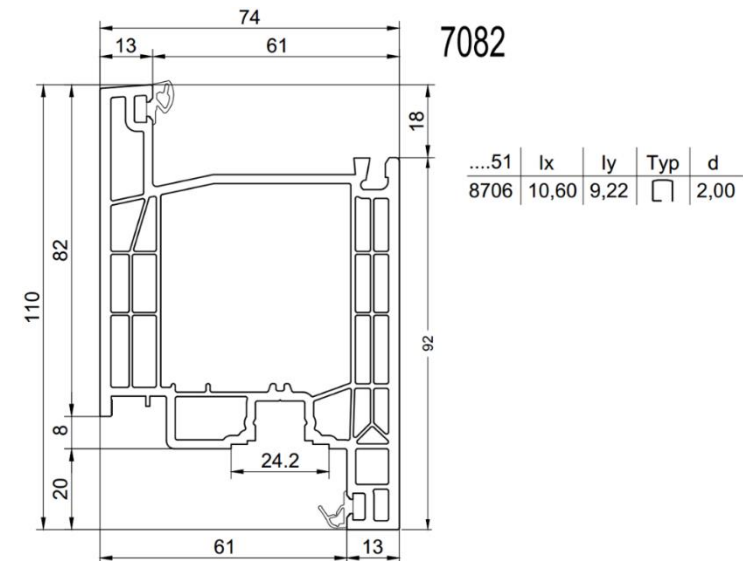
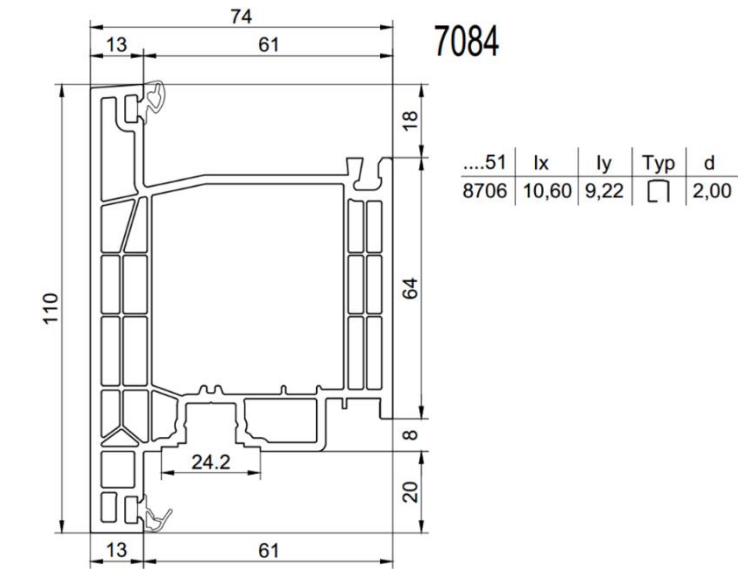

# GEALAN-LINEAR®



## System technology in detail

### Front door

- The sash profiles for front doors are also based on a proven stiffening concept from the S 8000 and S 9000 systems.
- The large steel chamber ensures excellent static properties.
- Stiffeners made of steel and aluminium are available, which can be used uniformly in both sash profiles.
- Matching weldable corner connectors are available.
- For increased static requirements the standard glass rebate allows the use of rebate stiffeners.

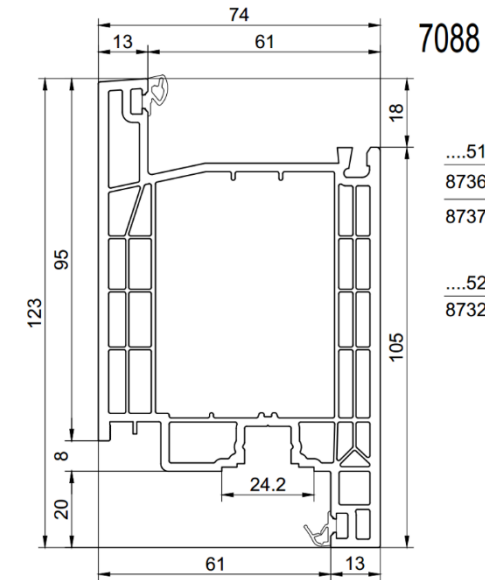

The large steel chamber provides excellent static properties

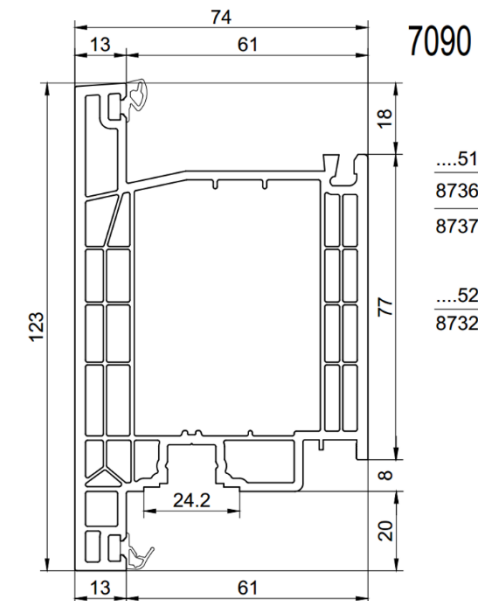

....51	lx	ly	Typ	d
8736	13,83	20,88		2,00
8737	13,83	20,88		2,00

....52	lx	ly	Typ	d
8732	16,81	27,51		2,00



....51	lx	ly	Typ	d
8736	13,83	20,88		2,00
8737	13,83	20,88		2,00

....52	lx	ly	Typ	d
8732	16,81	27,51		2,00

# GEALAN-LINEAR®

System technology in detail

# GEALAN-SMOOVIO®

- For the GEALAN-SMOOVIO® sliding system, an additional sash in the GEALAN-LINEAR look is available.
- The use of angular glazing beads is also possible.

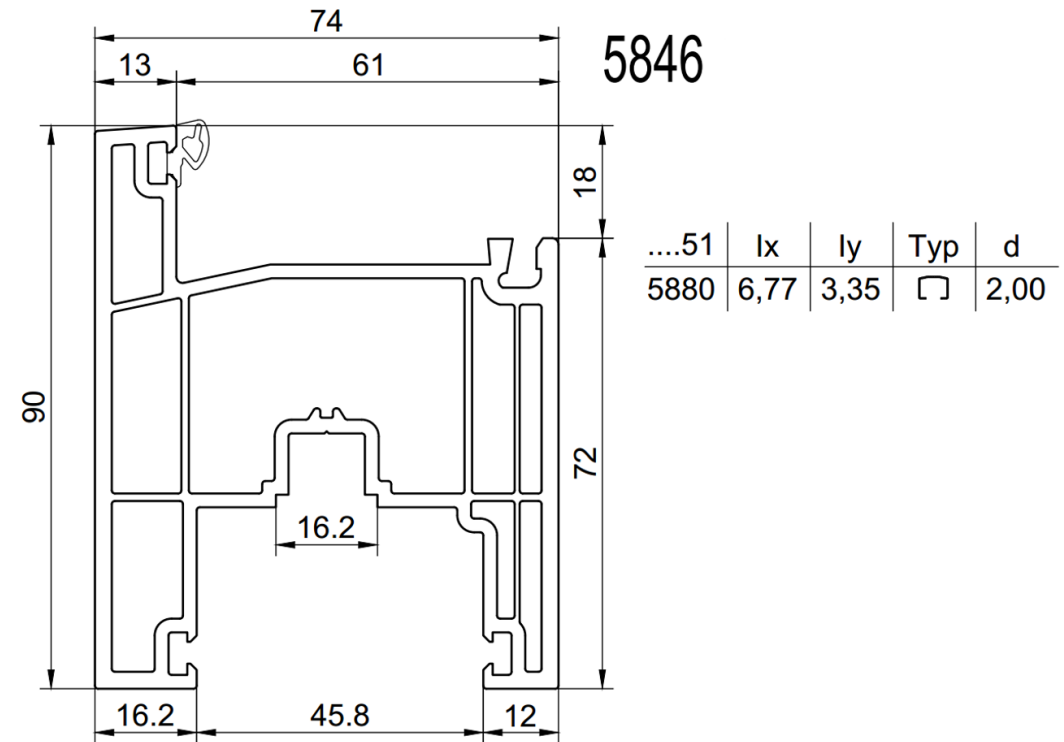

Integrated solution for objects with sliding doors or windows.

# GEALAN-LINEAR®

## System technology in detail

### Renovation frame

- The system is also available with two cover frames with inner limb for refurbishment and the realisation of market-specific installation situations.
- Six profile chambers ensure very good thermal insulation properties
- Welding to the frame is possible without inner limb.

Frame for market specific requirements

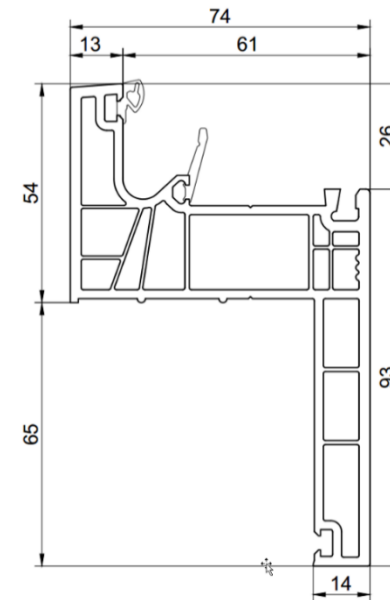

7027

....51	lx	ly	Typ	d
6744	1,24	0,59	□	1,50
6745	1,56	0,73	□	2,00

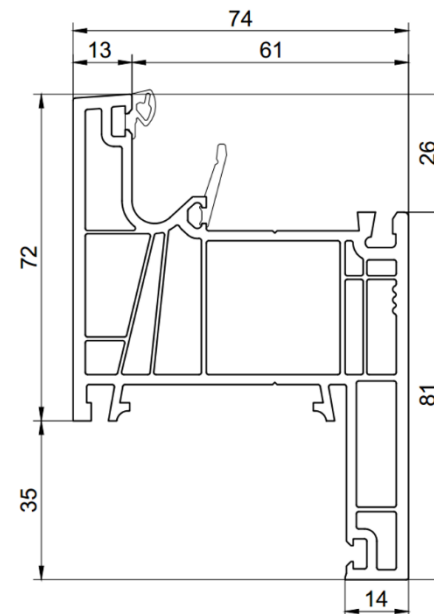

7023

....51	lx	ly	Typ	d
8715	1,90	1,90	□	1,50
8716	1,74	1,05	□	1,50
8727	2,20	1,35	□	2,00
5765	2,38	2,40	□	2,00
7736	0,86	0,64	┘	1,50

# GEALAN-LINEAR®

## System technology in detail

### 90° corner

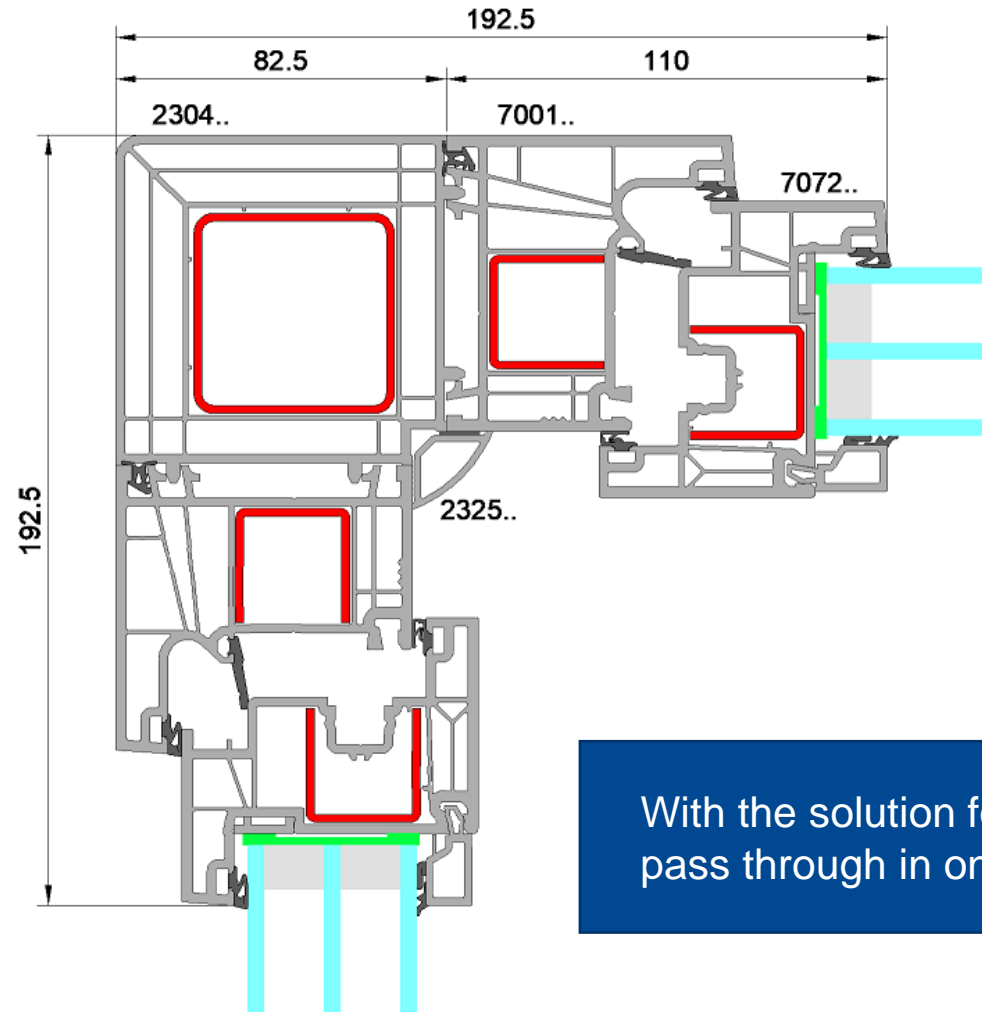

With the solution for the 90° corner, the weather sheets can pass through in one plane.

### Variable corner solution - 135° corner

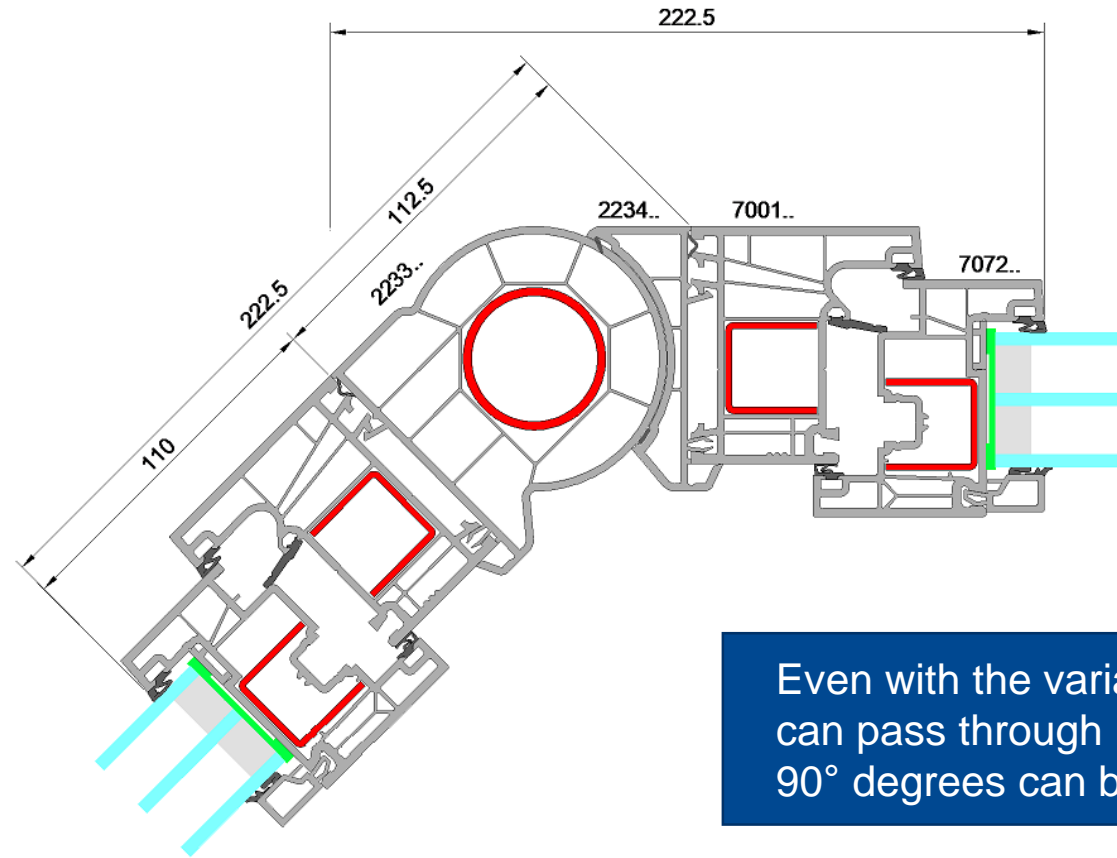

Even with the variable corner solution, the weatherboards can pass through in one plane. Angles between 180° and 90° degrees can be realised.

**Thank you for your attention!**